

CO 25 S / CO 50 S

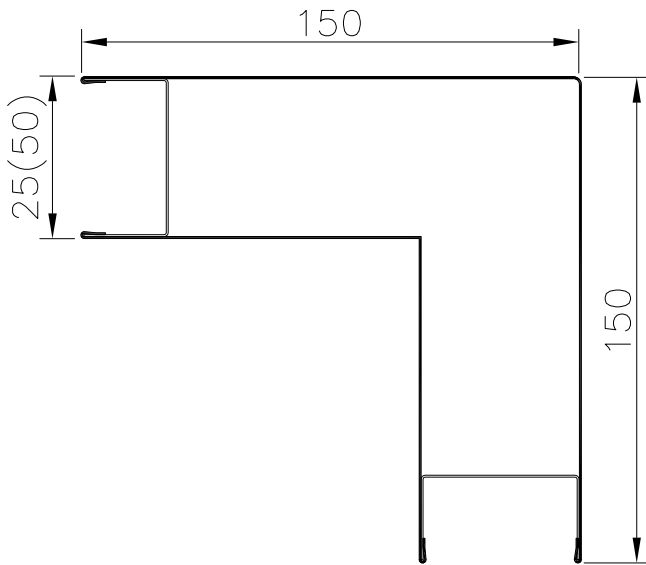

COD 25 / COD 50

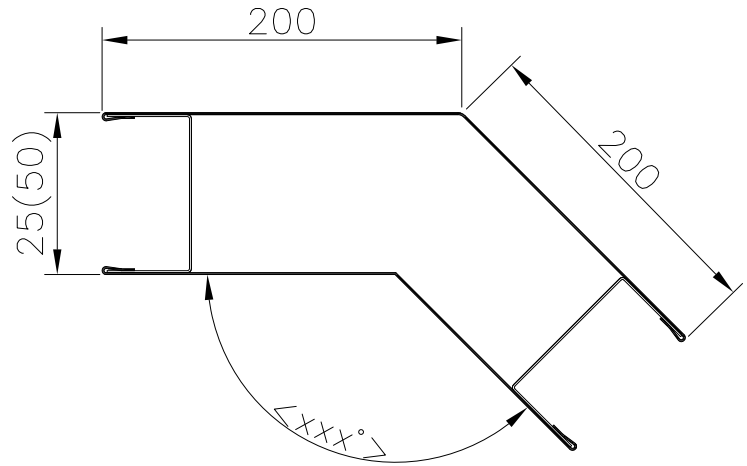

Examples of usage:

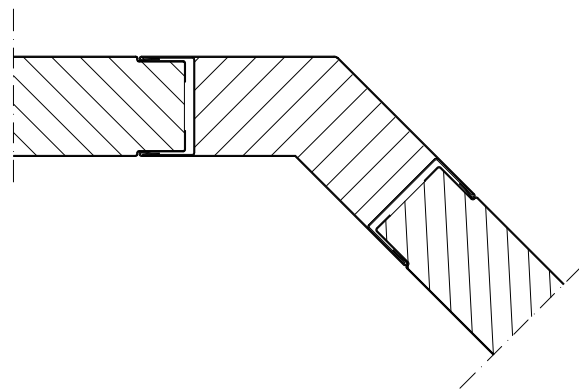
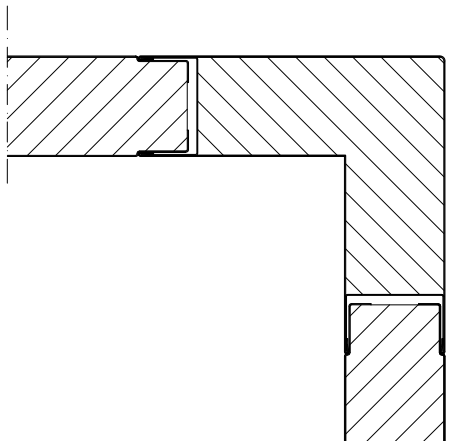

PANEL	CO 25 / CO 50	COD 25 / COD 50	Core material
Fire class	B-15	B-15	Material: mineral wool
Module width	150-600 mm	150-600 mm	Surface material
Module length	up to 2700 mm	up to 2700 mm	Material: galvanized steel sheet, stainless steel sheet
Thickness	25/50 mm	25/50 mm	Coating: PVC film, RAL
Sound red. (R _w) / weight	33 dB/36 dB	33 dB/36 dB	Fire class: low flame spread surface class1
Application	lining/partition	lining/partition	

Our products are produced according to our projects and documentation or customer's specification.